

ADVANCED HIGH CEILING 4" Cylinder Series - Adjustable Cable(DMX)



IMPORTANT SAFETY INFORMATION. READ AND FOLLOW ALL SAFETY INSTRUCTIONS

IMPORTANT SAFETY INFORMATION. READ AND FOLLOW ALL SAFETY INSTRUCTIONS. Before wiring to power supply and during servicing or relamping, turn off power at fuse or circuit breaker. All servicing or relamping must be performed by qualified service personnel. Product must be grounded to avoid potential electric shock or other potential hazard. Product must be at locations and at heights and in a manner consistent with its intended use, and in compliance with Electrical Code and local codes.

SAVE THESE INSTRUCTIONS FOR FUTURE REFERENCE.

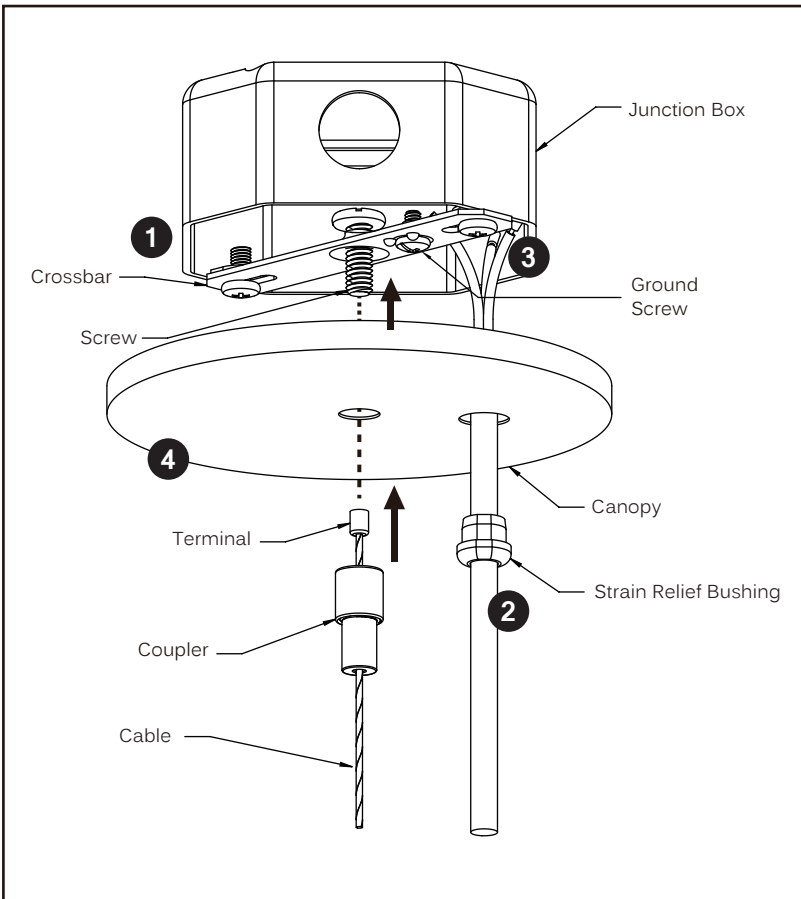

Step 1

Secure the crossbar to the 4" octagonal box (by others) designed to support the weight of the fixture.

Step 2

Lock the strain relief bushing to the power cord with allowance for wiring connections, and thread the power cord through the canopy wire hole.

Step 3

Connect the Green ground conductor to the ground screw on the crossbar, the line voltage to the Black conductor, and the neutral to the White conductor. For 0-10V dimming option, connect the two remaining conductors (Data+ to Purple conductor and Data- to Gray conductor).

* Make all connections with UL approved connectors.

Step 4

Thread the cable through the coupler with the terminal side on top. Slide the coupler up to the canopy and secure with the screw on crossbar.

ADVANCED HIGH CEILING 4" Cylinder Series - Adjustable Cable(DMX)

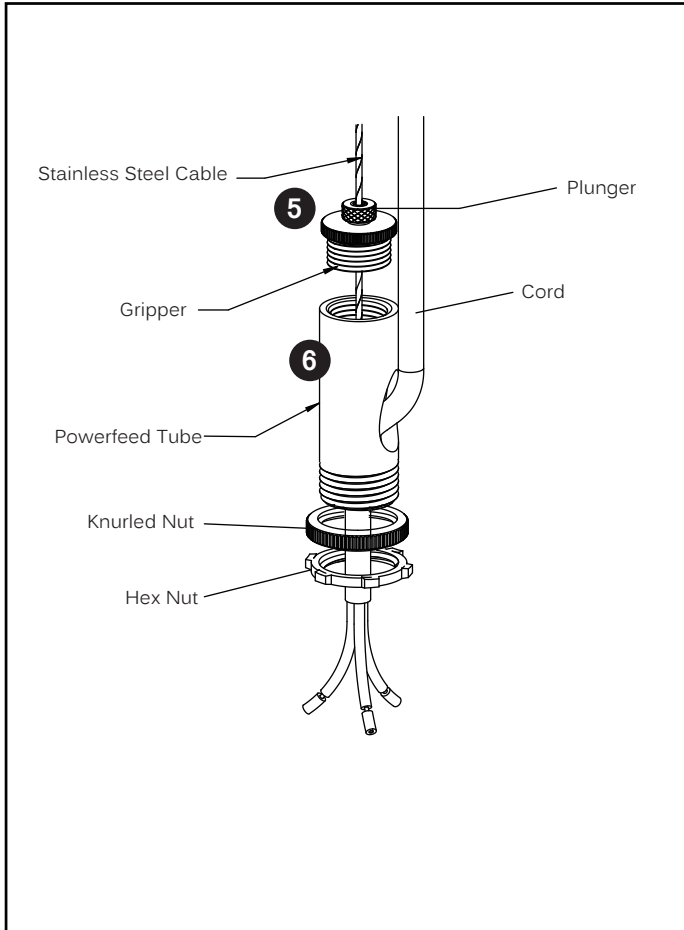

Step 5

Insert the cable through the gripper and plunger. Trim off extra cable using cable cutting tool.
To adjust the cable to desired length, press the plunger.

Step 6

Secure gripper with powerfeed tube, then feed cord through powerfeed tube.

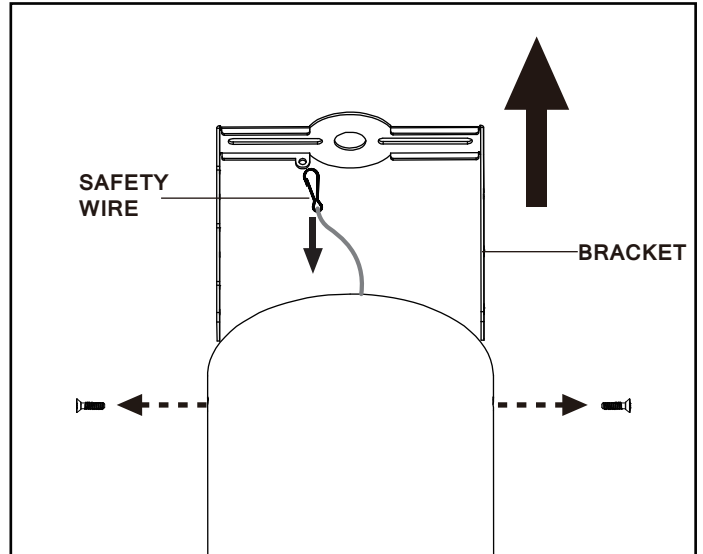

Step 7

Loosen two screws on the side of fixture and unhook the safety wire. Remove the bracket from fixture.

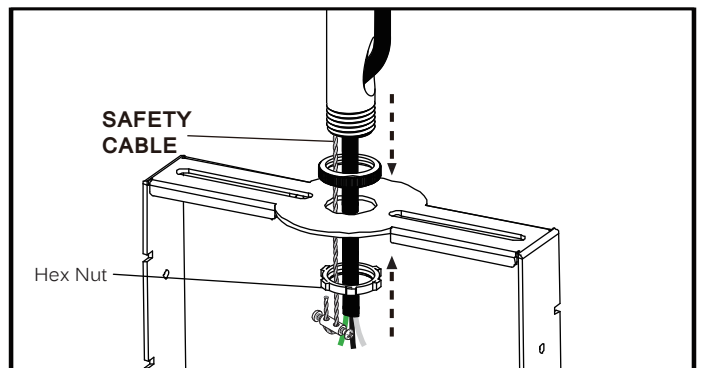

Step 8

Slide powerfeed tube through bracket and screw nuts on both sides of bracket. Ensure powerfeed tube is securely fastened to bracket.

ADVANCED HIGH CEILING 4" Cylinder Series - Adjustable Cable(DMX)

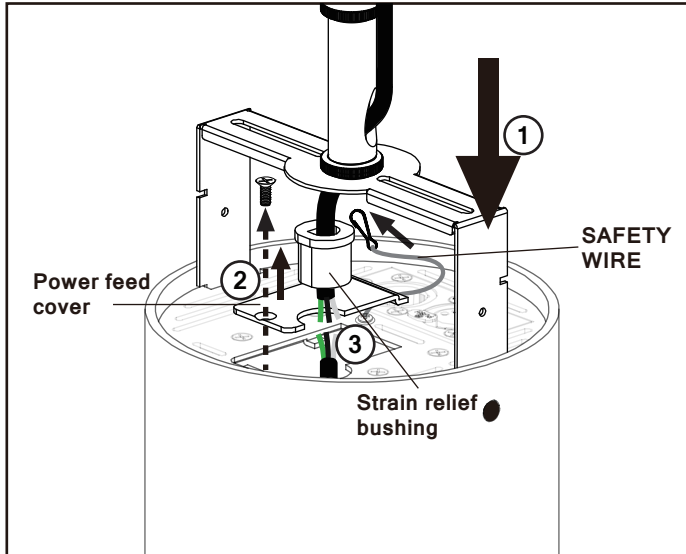

Step 9

1. Insert bracket into fixture, hook safety wire to bracket.
2. Loosen the screw and remove the power feed cover.
3. Make electrical connections inside fixture. See wiring diagrams.
*Cut the cord to the desired length and strip leads before connection.

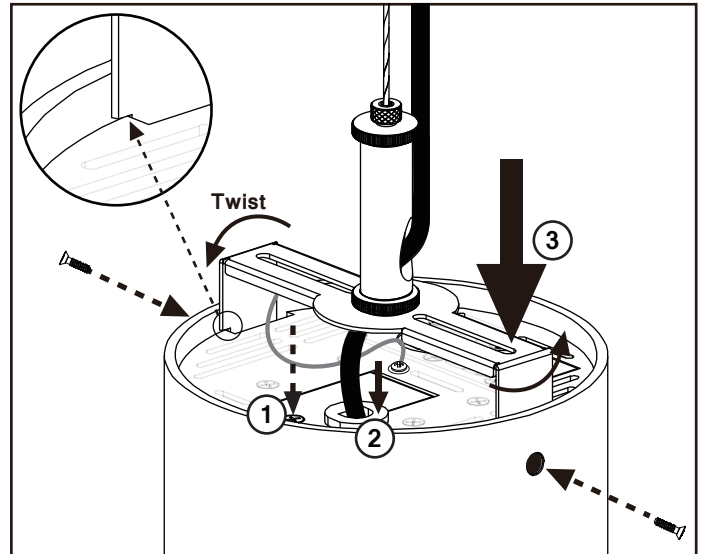

Step 10

1. Secure power feed cover on the lid.
2. Attach strain relief bushing to cord and insert it through the hole. Make sure strain relief bushing is secured.
3. Adjust the height of bracket by aligning the slots in bracket to the lid. See DMX bracket diagram below. Twist the bracket and secure by screws.

DMX

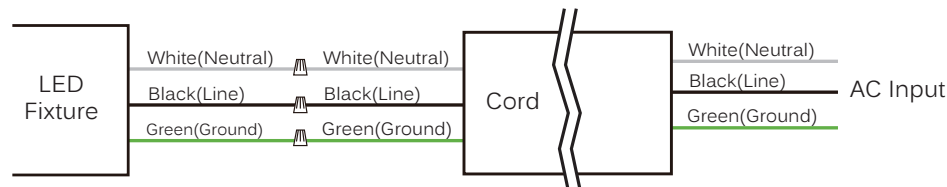

RJ45

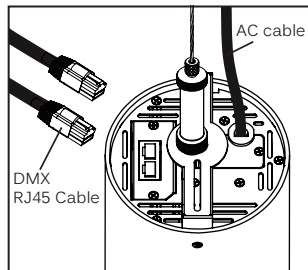

Connect DMX by using a standard shielded CAT5/6 cable.

XLR

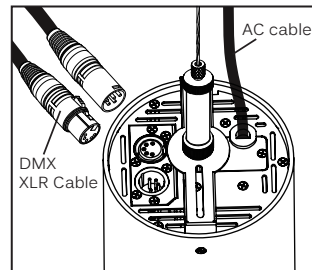

Connect DMX by using a standard DMX512 XLR cable with 5 pin in/out connector (by others).

DMX Bracket Diagram

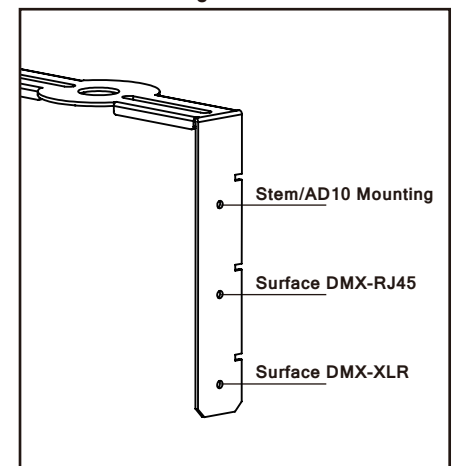

*The last fixture has to be terminated with a DMX Terminator (by others).